

# PERFORMANCE ANALYSIS ON PEAK-TO-AVERAGE POWER RATIO (PAPR) REDUCTION TECHNIQUES IN ORTHOGONAL FREQUENCY DIVISION MULTIPLEXING (OFDM) SYSTEM

Abdul Latiff, N.Adilah, Faculty of Science and Technology,UMT 1; Ishak, N.I.Aliyaa, Faculty of Science and Technology,UMT 2; Yusoff, M.Hafiz, Faculty of Science and Technology, UMT 3

## Abstract

A fundamental wireless transmission system, Orthogonal Frequency Division Multiplexing (OFDM) is widely used recently in wireless communication. However, practical implementation of OFDM introduced a major drawback known as peak-to-average power ratio (PAPR). This paper focused on the most three preferable techniques for reducing high PAPR. In general, Partial Transmit Sequence (PTS), Selective Mapping (SLM) and Clipping and Filtering can improve the PAPR statistic of an OFDM system using 16 QAM and 64 QAM modulation format regardless the number of sub-carriers. Simulation results demonstrate that the techniques can efficiently reduce the PAPR performance based on the number of subcarriers and modulation format that being used in the system.

## Introduction

Orthogonal Frequency Division Multiplexing (OFDM) is an effective multicarrier transmission technique in high-bit-rate wireless communication systems. OFDM gives a better performance since it tolerates to multipath delay spread, immune to the frequency selective channels and provides high spectral and power efficiency [1]. OFDM system being implemented in various wireless communication standards such as IEEE 802.11a standards for Wireless Local Area Networks (WLAN), IEEE 802.16a standards for Wireless Metropolitan Area Networks (WMAN), digital audio/video broadcasting, Terrestrial Digital Video Broadcasting (DVB-T), ETS 1 HIPERLAN/2 standard and high speed cellular [2].

One of the major drawbacks in OFDM systems is known as high peak-to-average power ratio (PAPR). This high PAPR is undesirable condition is occurring in nature environment where the sinusoid signal is added constructively at the same time, thus the high peak of the signal will be obtained. The high peak of the signal leads the OFDM system to the nonlinearity range of high power amplifier (HPA) and degrades the bit error rate (BER) by introducing the signal distortion. It also drags the signal into the out of band radiation and changes the signal constellation [3]. Generally, this

problem can be solved in two ways; by implementing the expensive power amplifier in which the transmitters of the system require a linear HPA with wide dynamic range; by modifying the signal. In this paper, we focused on comparing the PAPR reduction performance for the most three preferable techniques for PAPR reduction, Partial Transmit Sequence (PTS)[4], Selective Mapping [5] and Clipping and Filtering method [6]. The simulation results for these techniques are presented using Matlabsoftware.

## Orthogonal Frequency Division Multiplexing

### System Model

An OFDM symbol consists of  $N$  sub-carriers by the frequency spacing of  $\Delta f$ [7]. Thus, the total bandwidth  $B$  will be divided into  $N$  equally spaced subcarriers. All the subcarriers are orthogonal to each other within a time interval of length described by

$$T = 1/\Delta f \tag{1}$$

Where  $T$  is the original symbol period. Each subcarrier can be modulated independently with the complex modulation symbol  $X_{m,n}$  where  $m$  is a time index and  $n$  is a subcarrier index. Then, within the time interval  $T$  the following signal of the  $m$ -th OFDM block period can be described by

$$x_m(t) = \frac{1}{\sqrt{N}} \sum_{n=0}^{N-1} X_{m,n} g_n(t - mT) \tag{2}$$

where,  $g_n$  is defined through

$$g_n(t) = \begin{cases} e^{j2\pi n \Delta f t}, & 0 \leq t \leq T \\ 0, & \text{else} \end{cases} \tag{3}$$

where  $g_n(t)$  is a rectangular pulse applied to each subcarrier. The total continuous time signal  $x(t)$  consisting of all the OFDM blocks is given by

$$x(t) = \frac{1}{\sqrt{N}} \sum_{m=0}^{\infty} \sum_{n=0}^{N-1} X_{m,n} g_n(t - mT) \tag{4}$$

Now, consider a single OFDM symbol ( $m = 0$ ) without loss of generality. This can be shown because there is no overlap between different OFDM symbols. Since ( $m = 0$ ),  $X_{m,n}$  it can be replaced by  $X_n$ . Then, the transmitted OFDM signal is denoted by

$$x(t) = \frac{1}{\sqrt{N}} \sum_{n=0}^{N-1} X_n e^{j2\pi n \Delta f t}, 0 \leq t \leq T \quad (5)$$

If the bandwidth of the OFDM signal is  $B = N \times \Delta f$  and the signal  $x(t)$  is sampled by the sampling time  $\Delta t = \frac{1}{B} = \frac{1}{N \Delta f}$ , then the OFDM signal is in discrete time form and can be written as

$$x_k = \frac{1}{\sqrt{N}} \sum_{n=0}^{N-1} X_n e^{j2\pi k n / N}, k = 0, 1, \dots, N - 1 \quad (6)$$

where  $j = \sqrt{-1}$ ,  $n$  denotes the index in frequency domain and  $X_n$  are input symbols modulated by PSK or QAM in frequency domain.

## System Block Diagram

Figure 1 shows a typical system block diagram of basic FFT based OFDM system. The serial input data bit stream is converted to  $N$  parallel sub channels and mapped with a selected modulation scheme, resulting in  $N$  sub channels containing in complex number form. These complex values are then sent to the  $N$  channel IFFT. Then, the parallel signals are converted back to a serial sequence. A guard interval is inserted to reduce the effect of ISI caused by multipath propagation. Finally, the signal is converted to an analogue signal and converted back up to a form suitable for transmission. At the receiver, a reverse procedure is used to demodulate the OFDM signal. In OFDM system, a single tap equalizer is needed at the receiver to remove the ISI.

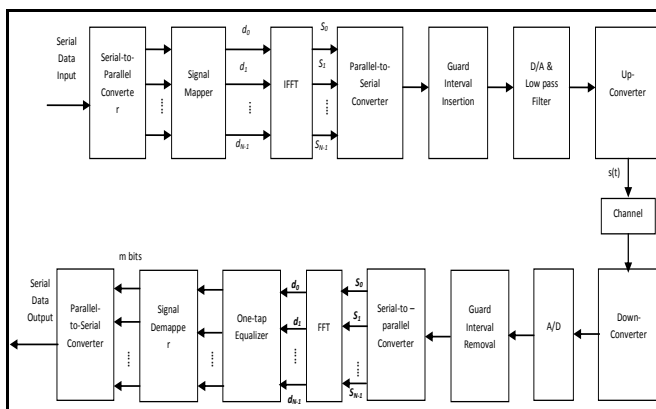

Figure 1. Basic FFT based of an OFDM systems

## Peak-to-Average Power Ratio (PAPR)

### PAPR Definition

In this chapter, a detailed mathematical analysis for PAPR is presented. The Root Mean Square (RMS) magnitude of the OFDM signal is defined as the root of the time average of the envelope power ( $\sqrt{\bar{P}}$ ) where  $\bar{P}$  is defined by

$$\bar{P} = \frac{1}{T} \int_{t=0}^T |x(t)|^2 dt = \frac{1}{N} \sum_{n=0}^{N-1} |X_n|^2 \quad (7)$$

where  $x(t)$  is the OFDM signal defined by (4). The value  $\bar{P}$  in this case corresponds to a single OFDM symbol, and depends on the sequence of information carrying coefficients  $\{X_n\}$ . The average power of OFDM symbols can be written as  $P_{av} = E\{\bar{P}\}$ .

Thus, the PAPR of an OFDM signal can be defined as follow by

$$PAPR = \frac{\max_{0 \leq t \leq T} \{|x(t)|^2\}}{P_{av}} \quad (8)$$

$$PAPR = \frac{\max_{0 \leq t \leq T} \{|x(t)|^2\}}{E\{|x(t)|^2\}} \quad (9)$$

If the input data power is normalized, then  $E\{|x(t)|^2\} = 1$  and the equations become as

$$PAPR = \max_{0 \leq t \leq T} \{|x(t)|^2\} \quad (10)$$

and

$$PAPR = \max_{0 \leq t \leq T} \left[ \frac{1}{N} \sum_{n=0}^{N-1} X_n e^{j2\pi n \Delta f t} \right]^2 \quad (11)$$

The theoretical expression for maximum of the PAPR for  $N$  number of sub-carriers is as

$$PAPR_{max} = 10 \log(N) \text{ dB} \quad (12)$$

Another parameter that related to PAPR is crest factor that defined as the square root of the PAPR as described as

$$\text{Crest Factor, } C.F = \sqrt{PAPR} \quad (13)$$

High PAPR as well as Crest Factor is major problem in OFDM system that occurs when the input signal is subjected to a transmitter that contains the non-linear components.

Thus, the high value of PAPR needs to be controlled in order to minimal the drawback.

## Problem with PAPR

The high PAPR is the major disadvantage in time domain OFDM systems. High PAPR results from the nature of the modulation itself where multiple subcarriers / sinusoid are added together to form the transmitted signal [8]. The high PAPR is the most unwanted circumstance because it leads to several problems such as:

- Strains the analogue circuitry
- Large range of dynamic linearity
- Result to expensive devices
- High power consumption
- Low efficiency of transmitted signal

## Techniques for PAPR Reduction

In this paper we are focusing on the most three popular reduction techniques for PAPR in OFDM system. The techniques details are discussed as follow:

### Partial Transmit Sequence

PTS technique starts with the input data block of  $N$  symbols that being partitioned into disjoint sub blocks. The subcarrier in each subblock is weighted by a phase factor for that subblock. The phase factors are selected such that the PAPR of the combined signal is minimized. This technique significantly reduce the PAPR, however, finding the optimal phase factors is a very complex problem. Thus, several extensions hadbeen done to minimize the computational complexity.

### Selective Mapping

The input data sequence is being multiplied by each of the phase sequences to generate alternative input symbol sequences. Each of the alternative input data sequences is made the IFFT operation, and then the one with the lowest PAPR is selected for the transmission.

### Clipping and Filtering

The generated OFDM signal is transferred to the clipping block [9]. When the amplitude exceeds the threshold value, the amplitude is hard-clipped while the phase is saved. The clipping process causes in-band distortion that lead to the degradation of BER and out-bands distortion will cause the interference to the neighboring channels. Thus, to reduce the distortion, a band-limiting filter is used. This technique is

significantly reducing the PAPR however the calculation cost increases proportionally to the number repeats and filtering delay also increases. Therefore, there are some tradeoff between PAPR and system cost.

## Modulation Scheme

Quadrature Amplitude Modulation (QAM) is a combination of Amplitude Shift Keying (ASK) and Phase Shift Keying (FSK) modulation techniques. This will give a maximum contrast between each signal unit (bit, dual-bit, tri-bit and so on) is achieved. The number of phase shift is greater than the number of amplitude shift. This is because of the amplitude susceptibility to noise. This modulation format is popular in radio communication system and data communication system because it achieves a greater distance between adjacent points in the I-Q plane by distributing the points more evenly. The more distinct the points on constellation, the more bit error will be reduced. When more possible bit per symbol can be transmitted with the same energy level of the constellation, the points are more close together, thus the transmission becomes more susceptible to the noise. This will give a higher bit error rate compare to lower QAM variant. In this way there is a balance between obtaining the higher data rates and maintaining an acceptable bit error rate for any radio communications system.

## Criteria for Choosing the PAPR Reduction Technique

There are several criteria that should be considered in order to choose the specific approach for PAPR reduction technique. These factors include PAPR reduction capability, power increase in transmitted signal, BER increase at the receiver, data rate reduction, computational complexity, and so on. [9]. The details of the factors are briefly explained as below.

### PAPR Reduction Capability

The capability of reducing the PAPR is the most important key in choosing right reduction technique. The technique must be able to reduce the PAPR without introduced the harmful effect. For example, the amplitude clipping technique clearly removes the time domain signal peaks, but results in in-band distortion and out-of-band radiation [10].

### Power Increase in Transmitted Signal

Power increment in transmitted signal is necessary for a several PAPR reduction techniques such as tone reservation and tone injection methods. Tone reservation needs more power for PAPR reduction carriers while tone injection method

requires more energy for a set of equivalent constellation point to reduce the PAPR. The power increment in the transmitted signal is not necessary for PTS, SLM and Clipping and Filtering techniques.

## BER Increase at the Receiver

This criterion is closely related to power increment in transmitted signal. Some techniques that have fix or equivalent transmitted power signal with the receiver power might be facing a BER increment problem at the receiver. This happen when applying the reduction techniques that require a larger transmitted signal power to maintain the BER performance. For example, the power increment in transmitted signal is not necessary for PTS and SLM techniques, thus the BER increases at the receiver if the side information received in error and the entire data block may be lost. For clipping and filtering, there is no BER increment.

## Data rate reduction

Loss in data rate may be required for some techniques in order to control the PAPR reduction. For instance, the block coding technique loss one out of four information symbols so that the PAPR reduction can be monitored. PTS and SLM techniques have the data rate reduction due to the side information used. These techniques might receive the error side information unless some form of prevention technique is applied. Side information is not necessary for the clipping and filtering technique, thus a very minimal data rate reduction occurred in this technique.

## Computational complexity

Generally, the technique with more complex of computational principal will perform a better PAPR reduction capability. For example, PTS technique used repeated iterations in order to achieve a better performance in PAPR reduction regardless the number of subcarriers in the systems. Table 1 shows the summarized for PAPR reduction technique criteria comparison for the three techniques.

**Table 1. Criteria Comparison for PAPR Reduction Technique**

Criteria	PTS	SLM	Clipping and Filtering
Distortion less	Yes	Yes	No
Power Increment	No	No	No
Loss in Data Rate	Yes	Yes	No

Process at Transmitter (Tx) and Receiver (Rx)	Tx: M IDFTs, $W^m$ complex Vector Sums Rx: Side Information Extraction, Inverse PTS	Tx : U IDFTs Rx : Side Information, Extraction, Inverse Slm	Tx : Amplitude Clipping and Filtering Rx : None
---	--	--	--

## Simulation and Analysis

### Simulation Initialization

A series of simulations was run to obtain the result for the three reduction techniques of PAPR using MATLAB R2010 software. Two cases of simulations for OFDM systems were performed, where the first case we used the 16 QAM modulation scheme with the number of total subcarrier are  $2^8 = 256$ ,  $2^9 = 512$  and  $2^{10} = 1024$  with the same Fast Fourier Transform (FFT) size which is 64. While the second case only differs in term of modulation format used which is 64 QAM and the rest of the parameter was the same. OFDM systems parameters for MATLAB are summarized in Table 2. The simulation ended with the graphical result as shown in Figure 2, Figure 3, Figure 4, Figure 5, Figure 6 and Figure 7.

**Table 2. OFDM System Parameters and Values**

Parameters	Value
Data rate	6Mbps up to 48Mbps
Modulation scheme	16 QAM and 64 QAM
Coding or channel	Adding White Gaussian Noise
FFT size	64
Number of total subcarriers	256, 512 and 1024
FFT period or symbol period	$1/\Delta f = 1/10^3 = 1ms$
Guard duration	One quarter of symbol period, $0.25ms$
Oversampling factor	4
Number of runs	1000

## Result and Analysis

The performance of PAPR reduction is presented in term of the cumulative distribution. Complementary Cumulative Distribution Function (CCDF) is usually used to analyse the PAPR performance of OFDM systems. Figure 2 shows the system with  $N = 256$  sub-carriers together with 16 QAM modulation scheme. The output for the PAPR reduction before and after processing the reduction technique is obtained. The difference in term of PAPR reduction between the conventional OFDM systems and the techniques implemented is clearly observed. Figure 2 presents both the original output from the optimum OFDM system and output from the applied techniques.

As could be seen, the PAPR performance of the system reflects that for the PTS technique, the maximum reduction in PAPR value is slightly more than 1.5 dBs While for the SLM technique the maximum reduction can be achieved more than 4.0 dBs The clipping and filtering technique perform the most reduction in term of PAPR value which is slightly more than 5.0 dB compared with the previous two techniques. The simulation result is illustrated graphically as Figure 2.

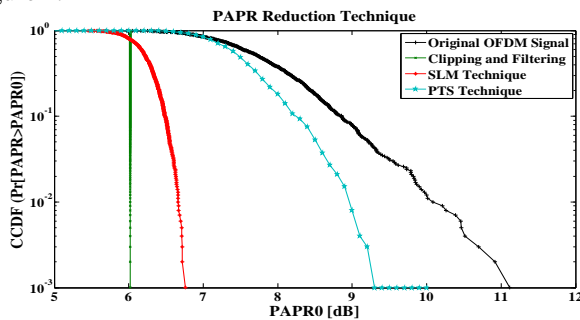

Figure 2. 16 QAM with Number of Subcarriers,  $N = 256$

The simulation was continued with  $N = 512$  number of total sub-carriers. The PAPR performance for PTS technique shows that the maximum reduction in PAPR value is slightly more than 1.5 dBs While for the SLM technique the maximum reduction can be achieved more than 4.0 dBs The clipping and filtering technique perform the most reduction in term of PAPR value which is slightly more than 5.0 dBs compared with the previous two techniques. The simulation result is illustrated graphically as Figure 3.

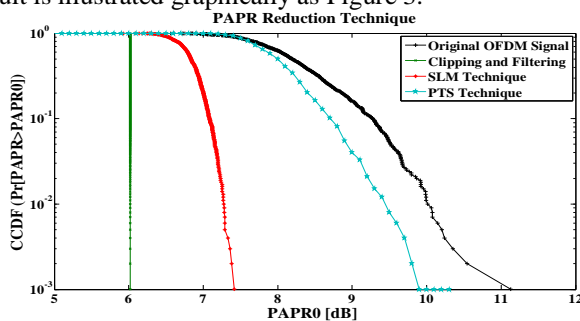

Figure 3. 16 QAM with Number of Subcarriers,  $N = 512$

The simulation result in Figure 4 represents the PAPR performance for  $N = 1024$  number of total sub-carriers. The PTS technique shows the capability of reduction in PAPR value is slightly more than 0.5 dB. While SLM technique performs the PAPR reduction value about 3.0 dB. The most reduction in term of PAPR value which is more than 5.0 dB is performed by the clipping and filtering technique.

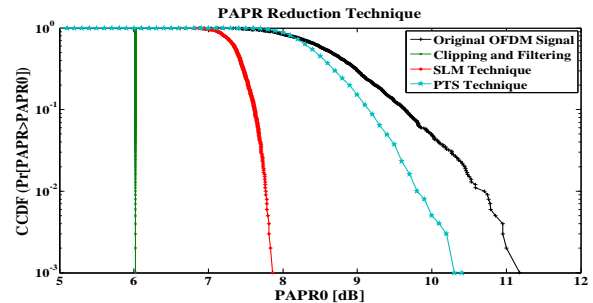

Figure 4. 16 QAM with Number of Subcarriers,  $N = 1024$

Figure 5, Figure 6 and Figure 7 show the simulation result for 64 QAM modulation format with number of sub-carriers,  $N = 256$ ,  $N = 512$  and  $N = 1024$  respectively. As shown in Figure 5, the PAPR performance illustrates that the PTS technique reduces PAPR value is about 0.7 dBs SLM technique performs more than 4.0 dB while clipping and filtering technique performs more than 5.0 dB in term of PAPR reduction value compared with the previous two techniques.

Figure 6 illustrates the PAPR performance for  $N = 512$  for the three techniques where the maximum reduction in PAPR value is slightly about 0.5 dB, 3.5 dB and 5.0 dB for PTS, SLM and clipping and filtering technique respectively.

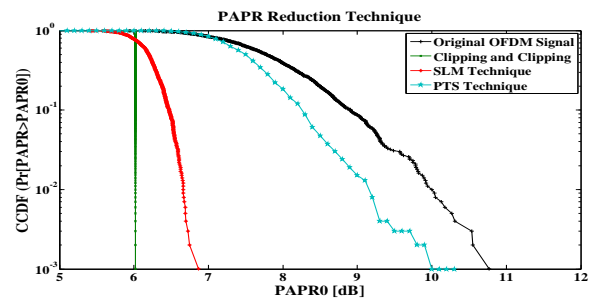

Figure 5. 64 QAM with Number of Subcarriers,  $N = 256$

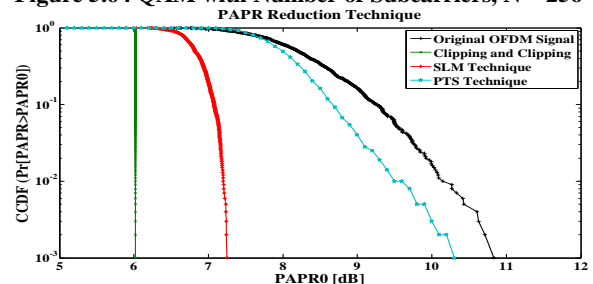

Figure 6. 64 QAM with Number of Subcarriers,  $N = 512$



The PAPR performance for  $N = 1024$  is demonstrated in Figure 7. PTS technique, the maximum reduction in PAPR value is slightly more than 0.4 dB. While SLM technique achieved more than 3.0 dB and clipping and filtering technique perform more than 5.0 dB which is the most reduction in terms of PAPR value compared with the previous two techniques. The overall simulation results show that these three techniques are potentially reduced the PAPR performance for OFDM systems.

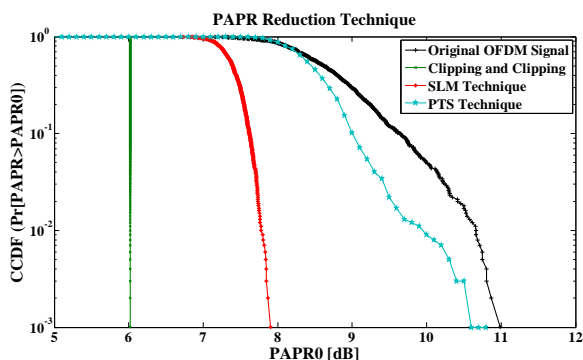

Figure 7.64 QAM with Number of Subcarriers,  $N = 1024$

Table 3 represents the summarized of PAPR reduction performance for the three different techniques that we have discussed throughout this paper.

Table 3. PAPR Reduction Performance

Modulation Scheme	Number of sub-carriers, $N$	Original OFDM	PTS Method	SLM Method	Clipping and Filtering
16 QAM	256	11.11 dB	9.30 dB	6.76 dB	6.0 dB
	512	11.13 dB	9.90 dB	7.42 dB	6.0 dB
	1024	11.18 dB	10.30 dB	7.86 dB	6.0 dB
64 QAM	256	10.77 dB	10.00 dB	6.86 dB	6.0 dB
	512	10.83 dB	10.30 dB	7.25 dB	6.0 dB
	1024	10.98 dB	10.60 dB	7.91 dB	6.0 dB

## Conclusion

PAPR is the major drawback in OFDM system. It is undesirable condition for the signal because it will distort the transmitted signal at the receiver. In this paper we have discussed the most three techniques for reducing the PAPR in OFDM systems. The result shows that these three techniques significantly reduce the PAPR performance. In this paper, it clearly shown that, the clipping and filtering technique perform the best result as it contributes the most reduction in PAPR performance value. There are many techniques that can be implemented to reduce the PAPR in OFDM systems. Each of them has its own advantages and disadvantages.

Although they can reduce the PAPR, they also have potential to provide extension reduction at the cost of loss in data rate, transmit signal power increase, BER increase and computational complexity increase. It has been suggested that PAPR reduction technique should be wisely chosen according to specific criterion for the system requirements.

## References

- [1] T. Ya-Fei, D. Rong-hua, Y. Xiao-an and T. Hai-wei, "PAPR Reduction of OFDM Signals using Modified Partial Transmit Sequences," 2009.
- [2] V. Seema, S. Pawan, A. Shivani and H. Pallavi, "Partial Transmit Sequence with Convolutional Codes for Reducing the PAPR of the OFDM Signal," pp. 70-73, 2011.
- [3] G. M. I. Abolfazl and G. S. M. I. T. Aoran, "PAPR Reduction of OFDM using PTS and Error-Correcting Code Subblocking," *IEEE Transaction on Wireless Communications*, vol. 9, no. 3, pp. 980-989, March 2010.
- [4] M. Stefan H. and H. Johannes B., "OFDM with Reduced Peak-to-Average Power Ratio by optimum Combination of Partial Transmit Sequences," 1997.
- [5] R. W. Bauml, R. F. Fisher and J. B. Huber, "Reducing the Peak-to-average Power Ratio of Multicarrier Modulation by Selected Mapping," *IEE Electronics Letters*, vol. 32, no. 22, pp. 2056-2060, Oct 1996.
- [6] A. K. Gurung, F. S. Al-Qahtani, A. Z. Sadik and Z. M. Hussain, "Power Savings Analysis of Clipping and Filtering Method in OFDM Systems," *ATNAC 2008*, pp. 204-208, 2008.
- [7] A. A. Abdul Wahab and M. F. Ain, "Journal of Engineering and Technology Research," *Peak to average power ratio reduction in OFDM systems using selected mapping and statistical redistribution*, vol. 2, no. 10, pp. 189-194, October 2010.
- [8] V. Vijayarangan and D. (. R. Sukanesh, "An Overview of Techniques for Reducing Peak to Average Power Ratio and Its Selection Criteria for Orthogonal Frequency Division Multiplexing Radio System," *Journal of Theoretical and Applied Information Technology*, pp. 25-36, 2005.
- [9] P. Sharma and S. Verma, "IJCSI International Journal of Computer Science Issues," *Performance Analysis of Peak-to-Average power Ratio Reduction Techniques for Wireless Communication Using OFDM Signals*, vol. 7, no. 6, pp. 261-267, November 2010.
- [10] L. Jae Hong and H. Seung Hee, "Overview of Peak-to-

Average Power Ratio Reduction Techniques for Multicarrier Transmission," *IEEE Wireless Communications*, pp. 56-65, April 2005.

## Acknowledgments

The authors would like to thank all those who had contributed towards making this research successful. Also, we are thankful to IJATER Journal for the support to develop this document.

## Biographies

**ABDUL LATIFF, N. ADILAH** received the B.Eng. degree in Electrical and Electronic Engineering from the University Science of Malaysia, Penang, Malaysia in 2002, the M.Sc. degree in Communication and Signal Processing from the Newcastle University, Newcastle Upon Tyne, UK in 2004, and the Ph.D. degree in Computer and Communication Engineering from the University Malaysia of Perlis, Perlis, Malaysia in 2011 respectively. Currently, she is a Senior Lecturer of Communication and Computer Engineering at University Malaysia of Terengganu. Her teaching and research areas include communication engineering, wireless sensor network, computer network and embedded system design. Dr. Nurul Adilah Abdul Latiff may be reached at [nurul\\_adilah@umt.edu.my](mailto:nurul_adilah@umt.edu.my).

**ISHAK, N.I ALIYAA** received the Bachelor Degree in Electronic Engineering from University Sains Malaysia, Pulau Pinang, Malaysia, in 2012. Currently, she is studying Master of Physics majoring in Signals and System at Universiti Malaysia Terengganu.

**YUSOFF, M. HAFIZ** received the B.Sc degree in Information Technology from the University Utara Malaysia, Kedah, Malaysia in 2001, the M.Sc. degree in Computer Science from the University Science of Malaysia, Penang, Malaysia in 2005, and the Ph.D. degree in Computer Science from the Newcastle University, Newcastle Upon Tyne, UK in 2010 respectively. Currently, he is a Senior Lecturer of Computer Science at University Malaysia of Terengganu. Dr. Mohd Hafiz Yusoff may be reached at [hafiz.yusoff@umt.edu.my](mailto:hafiz.yusoff@umt.edu.my).